

# Motorized Card Reader

## Smart card/Contactless/Magnetic in one MOT 800 series

### Features

- **Smart card EMV 4.3 Level 1 Certified, Class A and Class B**  
ISO7816 with T=0/T=1, Class A and Class B
- **Contactless card** support ISO/IEC 14443 Type A & B from 106 kbps to 847 kbps
- **SAM card** up to 6 interface , support ISO7816 with T=0 /T=1.
- **Magnetic card** supports ISO7810/7811 magnetic card reading only.
- **Bezel with LED light:** provides card insertion indication and/or lighting and prevents the card being left inside.
- **Mechanical shutter** for protection against dust and/or the other foreign materials in the bezel position: enhances the reliability of the card reader.
- **Security function:** effectively precludes unauthorized card reading.

### Application

- P.O.S.
- Kiosk
- Banking & Payment
- Security & Identification, Access Control
- Vending system
- Customer Loyalty
- Ticketing machines



### Ordering Information

Model number	Magnetic Card Track 1, 2 &3 (Read)	IC Card	Contact -Less Card	SAM * 6	Interface	Bezel	Built-in Shutter	Card Ejection	Cable	Cover
<b>MOT800 -3RSVK</b>	ISO7810/7811	ISO7816 EMV4.3 Class A, B	ISO 1443 Type A/B	<b>With</b>	RS232	Transparent /led /short	Yes	Front /Back	Yes	Metal
<b>MOT800 -3RNVK</b>	ISO7810/7811	ISO7816 EMV4.3 Class A, B	ISO 1443 Type A/B	<b>Without</b>	RS232	Transparent /led /short	Yes	Front /Back	Yes	Metal

### **Certification:**

**\*\* EMV 4.3 Level 1 Approval Number: 15919 0318 430 43a 43a FIMT**

**\*\* FCC ID:2AO2NMOT800**

**\*\* CE**

## MOT 800 series

### Specification

<b>Electrical</b>	
Power Requirement	DC 12V± 5%
Power Consumption	Stand-by 200mA Max. 1.5A
Communication	RS232; (USB optional) Default 9600,n,8,1
<b>Mechanical</b>	
Body Material	ABS
Dimension	161 x 90 x 64.5 mm
Weight	Approx. 650g
Card Handling Method	MSR: Insert; IC Card: Landing; Contact less: Insert
Certification	<b>EMV version 4.3 Level 1 Approved, FCC, CE</b>
<b>Environment</b>	
Operation	0°C ~ 50°C; 5% ~ 90% humidity without condensation
Storage	-25°C ~ 70°C; 5%~ 90% humidity without condensation
<b>Performance</b>	
Card Type	Mag. Card ISO 7811
	IC card, ISO 7816, EMV4.3, Class A and B
	Contactless card ISO/IEC 14443 Type A & B
	SAM card ISO 7816, EMV4.0 Class A · up to 6
Magnetic Coercivity	Read 300~4000Oe
Card Thickness	0.76 +/- 0.08mm
Mag. Head Life	800K passes
IC Card Contact life	500K operations
MTBF	Electronics: 100,000.hours.

# MOT 800 series

## Engineering Data

### Power Supply Circuit Diagram

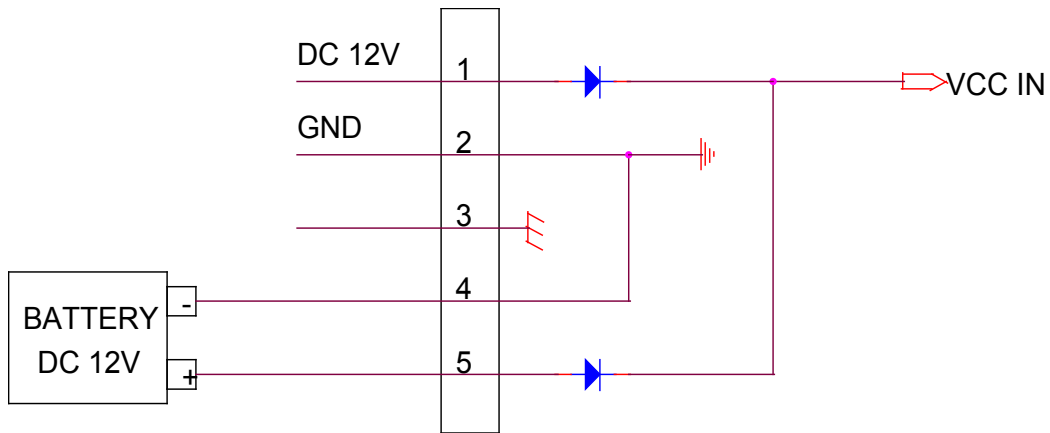

### I/O Information

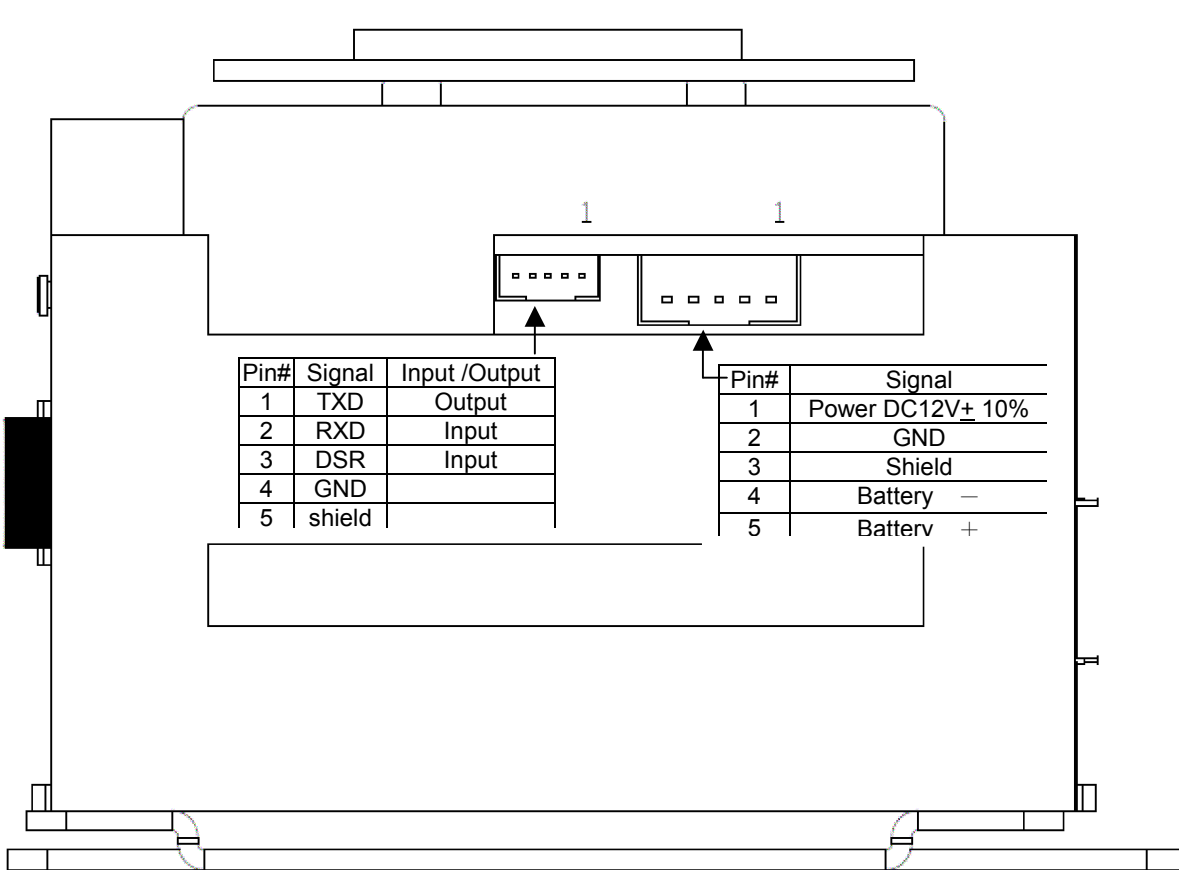

# MOT 800 series

## Dimension

Unit: mm

